

- 200 W.O.G.
- Conforms to BS 5154
- Screwed Ends

NOMENCLATURE AND MATERIALS

NO.	PART	MATERIAL	SPEC.JIS	SPEC.ASTM
1	NUT	STEEL	S10C	AISI-1010
2	NAME PLATE	ALUMINUM	A1100P	B209-1100
3	HAND WHEEL	CAST IRON	FC20	A48 CLASS / NO.35
4	STEM	BRASS	C3604B	B16-C36000
5	PACKING NUT	BRASS	C3604B	B16-C36000
6	GLAND PACKING	RUBBER	SAME AS NBR	SAME AS NBR
7	BONNET	FORGED BRASS	C3771B	B124-C37700
8	BODY	CAST BRASS CAST BRONZE	YBSC3 BC6	B584-C85700 B584-C83600
9	DISC	BRASS	C3604B	B16-C36000

Test pressure : Shell 300 PSI (20.7bar) (Hydrostatic)
Seat 200 PSI (13.8bar) (Hydrostatic)



BRASS FIG : F1131
BRONZE FIG : F1231

DIMENSIONS-QUANTITIES

F1131
F1231

NOMINAL SIZE	DIMENSION (mm)				PCS	
	L	H	D	d	Carton	Case
1/2"	48	68	54	12.5	120	300
3/4"	53	77	54	13.5	100	300
1"	63	86	61	19	60	180
1 1/4"	73	101	75	24	40	100
1 1/2"	81	106	75	32	32	80
2"	94	130	81	38	20	60

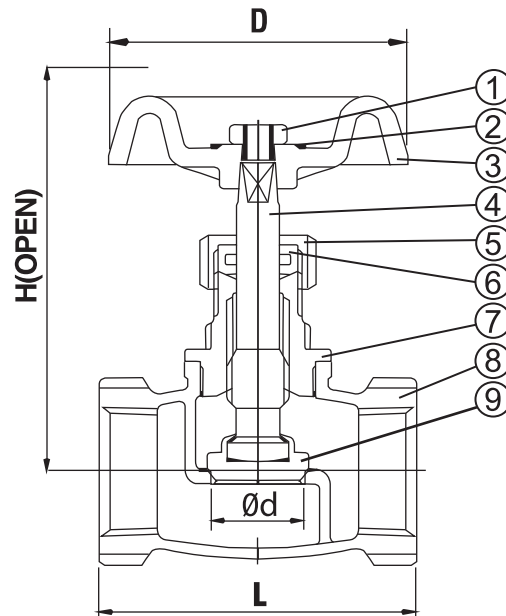

MANUFACTURED BY:

 **Fu San Machinery Co., Ltd.**
22, Lane 89, Sec 4, Chang Mei Road,
Ho-Mei Town, Chang-Hua, Taiwan
Tel : 886 4 756-2131
Fax : 886 4 756-2130
Web : www.fusan.com.tw

DISTRIBUTED BY:

 **Maxwell Valve Industry Sdn. Bhd.**
No. 26, Jalan Utama 2/28,
Taman Perindustrian Puchong Utama,
47100 Puchong, Selangor Darul Ehsan, Malaysia
Tel : 60(3) 8060 3325 Fax : 60(3) 8060 3341
Email : sales@maxwellvalve.com
www.maxwellvalve.com