

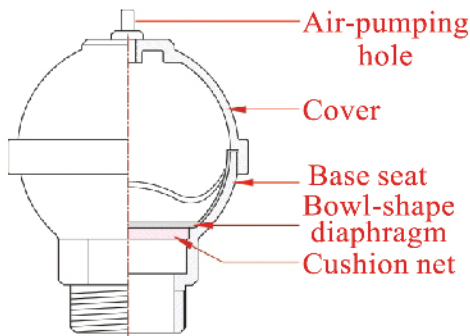

Patent Number : 140580

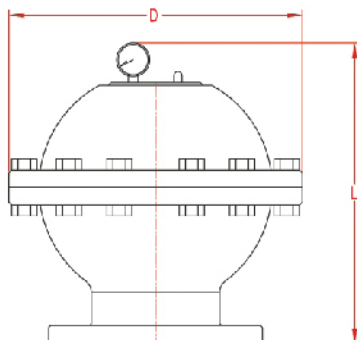

▲ Thread end(AIT)  
Without Pressure Gauge



▲ Flang end (AIF)  
With Pressure Gauge

- ▶ If the fluid is acid/alkaline or oil, the air bag made of special material should be applied.
- ▶ Vertical, horizontal and upside-down installation is acceptable.
- ▶ Please contact us for special fluid and temperature.
- ▶ Normal air chamber pressure : 2.5 bar
- ▶ Diaphragm material : NBR & Viton

(Thread end)

Item No	Thread(PT)	L (mm)	D (mm)	Weight(kg)	Air Chamber(cm <sup>3</sup> )
AIT-15	1/2"	74	46	0.3	17
AIT-20	3/4"	82	52	0.4	30
AIT-25	1"	95	62	0.5	65
AIT-40	1.5"	120	110	1.4	250
AIT-50	2"	162	135	3.2	650
AIT-65	2.5"	180	155	3.9	1125
AIT-80	3"	218	188	9	2000
AIT-100	4"	260	238	14	4400

• Stock Items

Material	Test Pressure	Max Applied Pressure	1/2"	3/4"	1"	1.5"	2"	2.5"	3"	4"
Bronze	21	10	•	•	•	•	•	•	•	•

(Flange end)

Item No	Flange	L (mm)	D (mm)	Weight (kg)	Air Chamber(cm <sup>3</sup> )
AIF-80	3"	240	155	18	2465
AIF-100	4"	330	330	31	5535
AIF-125	5"	330	330	32	5535
AIF-150	6"	420	400	67	15325
AIF-200	8"	510	460	93	27230
AIF-250	10"	510	460	103	27230
AIF-300	12"	620	625	198	67860

• Stock Items

Material	Test Pressure	Max Applied Pressure	3"	4"	5"	6"	8"	10"	12"
Bronze	21	12	•	•	•	•	•	•	•
Ductile Iron	21	12	•	•	•	•	•	•	

Stainless Steel Material Available upon order in Advance

MANUFACTURED BY:



**ELITE LINE INDUSTRIAL CORP.**  
 No. 40, Jialing St., Cianjhen District, Kaohsiung, Taiwan  
 Tel :886 7 331-1060  
 Fax :886 7 331-0100  
 Web :www.watervalve.com.tw

DISTRIBUTED BY:



**Maxwell Valve Industry Sdn. Bhd.**  
 No. 26, Jalan Utama 2/28, Taman Perindustrian Puchong Utama,  
 47140 Puchong, Selangor, Malaysia.  
 Tel :60(3) 8060 3325 Fax :60(3) 8060 3341  
 E-mail:sales@maxwellvalve.com  
 www.maxwellvalve.com